



# **High ductile 6xxx and high strength 7xxx Aluminum Sheets for advanced "BIW" lightweight design**

AluMag Roadshow - 19. to 26. March 2012

Dirk Van Nieuwerburgh



## Aleris International Inc.

---

**Aleris is a global leader in the production and sale of aluminum rolled and extruded products, recycled aluminum, and specifications alloy manufacturing**

**Global Headquarters in Beachwood, OH, a suburb of Cleveland (USA)**

**Approximately 42 production facilities in North America, Europe, South America and Asia**

**Approximately 7,000 employees**



- **Portfolio 6xxx qualities**
- **Supply references**
- **Pre-treatment & lubrication**
- **Automotive grades 5xxx**
- **7xxx product development**
- **R&D set up**



## **PORTFOLIO 6xxx QUALITIES**



## EN 6016 Monosheet Uni-alloy portfolio

Outer Panels			
Superlite <sup>®</sup> 160 ST	Standard		EN6016
Superlite <sup>®</sup> 200 ST	Standard		EN6016
Superlite <sup>®</sup> 200 RF	Roping Free		EN6016
Superlite <sup>®</sup> 200 IH	Improved Hemming		EN6016
Superlite <sup>®</sup> 200 IF	Improved Forming		EN6016
Superlite <sup>®</sup> 220 ST	Standard		EN6016
Inner panels & Structural Parts			
Ecolite <sup>™</sup> 160 ST	Standard		EN6016
Ecolite <sup>™</sup> 160 RO	Roping Optimised		EN6016
Ecolite <sup>™</sup> 210 ST	Standard		EN6016
Ecolite <sup>™</sup> 210 RO	Roping Optimised		EN6016
Ecolite <sup>™</sup> 250 ST	Standard		EN6016

All "EN 6016"



## Aleris alloys versus other standards

- No or only partly overlap with 6014, 6181 and 6451
- No V in Aleris 6xxx alloys : unnecessary element (contamination of scrap)
- Aleris 6016 type qualities have similar properties to other alloys (mechanical values, hemming, roping)

		<b>6014</b>	<b>6181</b>	<b>6451</b>	<b>6016</b>	<b>6016A</b>	<b>Aleris range</b>
<b>Si</b>	<b>(%)</b>	0,30-0,6	0,8-1,2	0,6-1,0	1,0-1,5	0,9-1,5	0,8-1,4
<b>Fe</b>	<b>(%)</b>	< 0,35	< 0,45	< 0,40	< 0,50	< 0,50	< 0,35
<b>Cu</b>	<b>(%)</b>	< 0,25	< 0,10	< 0,40	< 0,20	< 0,25	< 0,20
<b>Mg</b>	<b>(%)</b>	0,40-0,8	0,6-1,0	0,40-0,8	0,25-0,6	0,2-0,6	0,3 - 0,7
<b>Mn</b>	<b>(%)</b>	0,05-0,20	< 0,15	0,05-0,40	< 0,20	< 0,20	< 0,20
<b>V</b>	<b>(%)</b>	0,05-0,20		< 0,10			< 0,05

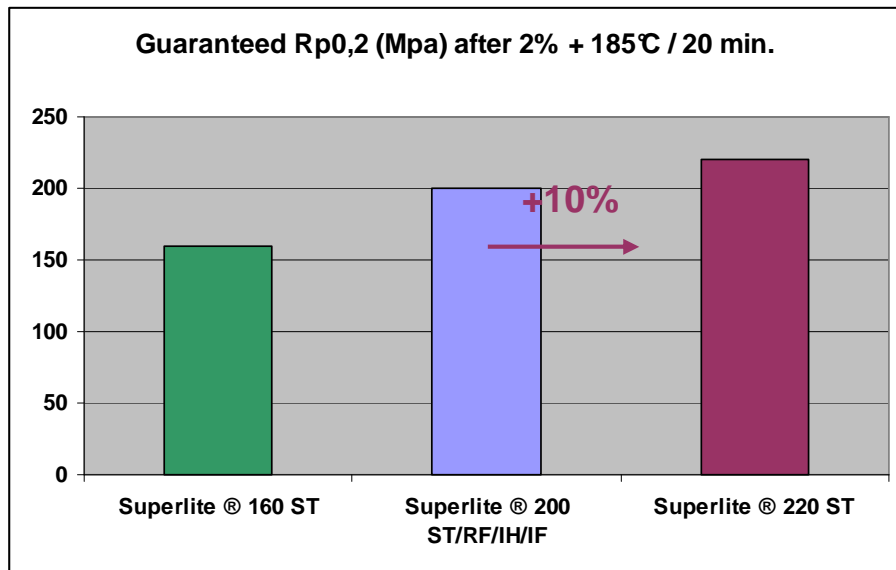

		Superlite <sup>®</sup>					
		160 ST	200 ST	200 RF	200 IH	200 IF	220 ST
T4 As delivered	Rm (Mpa)	200-240	200-250	200-250	200-250	200-250	220-270
	Rp0,2 (Mpa)	90-120	90-130	90-130	90-130	90-130	110-150
	Au (%)	min.20	min.20	min.20	min.20	min.22	min.20
	A80 (%)	min.24	min.24	min.24	min.24	min.26	min.23
	n 5%	min.0,28	min.0,27	min.0,27	min.0,27	min.0,28	min.0,27
	delta r 10%	max.0,30	max.0,33	max.0,20	max.0,33	max.0,20	max.0,30
after 2% + 185°C/20min	Rp0,2 (Mpa)	min.160	min.200	min.200	min.200	min.200	min.220

**Outer Panels = Superlite<sup>®</sup>**

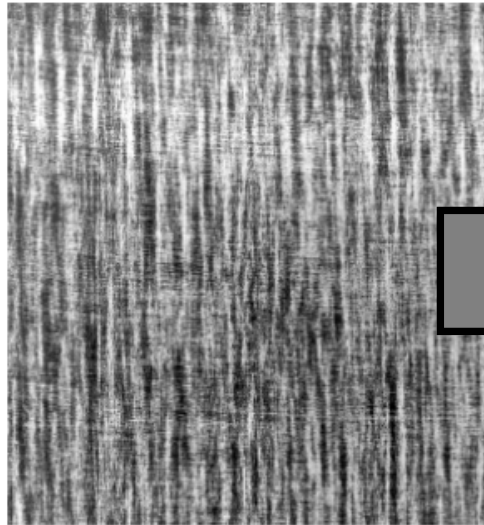

5

Güte: Ecolite 160/210/250

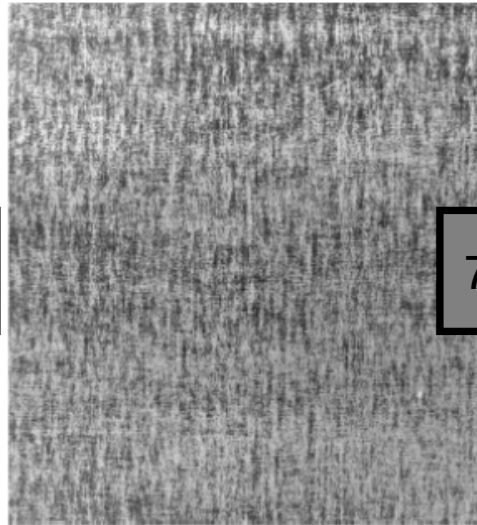

7.5

Güte: Superlite 200 ST/IH

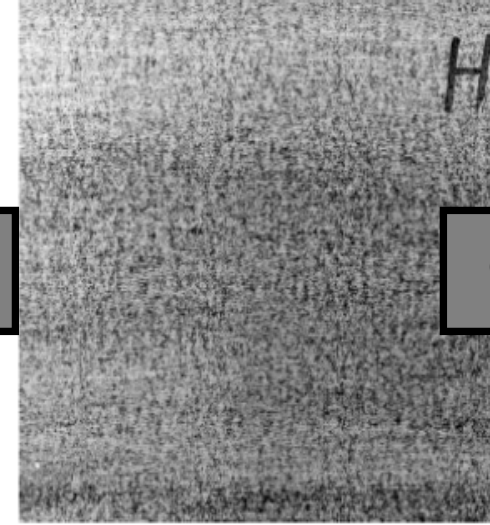

9

Güte: Superlite 200 RF

- Sample 100 x 300 mm 15% stretched perpendicular to rolling direction
- Slightly grinded with P800 sandpaper
- Visual inspection and rating 1-10

**Superlite<sup>®</sup> 200 RF for panels heavily stretched  $\perp$  to rolling direction**



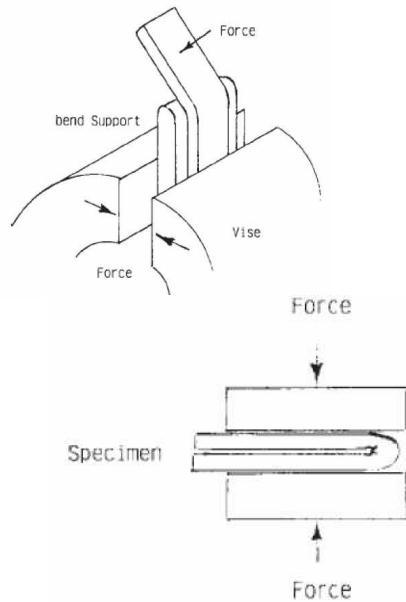

**Legend:**

5	No visual defect	
4	Mild surface roughening	
3	Severer surface roughening	
2	Small surface cracks	
1	Continuous surface crack	

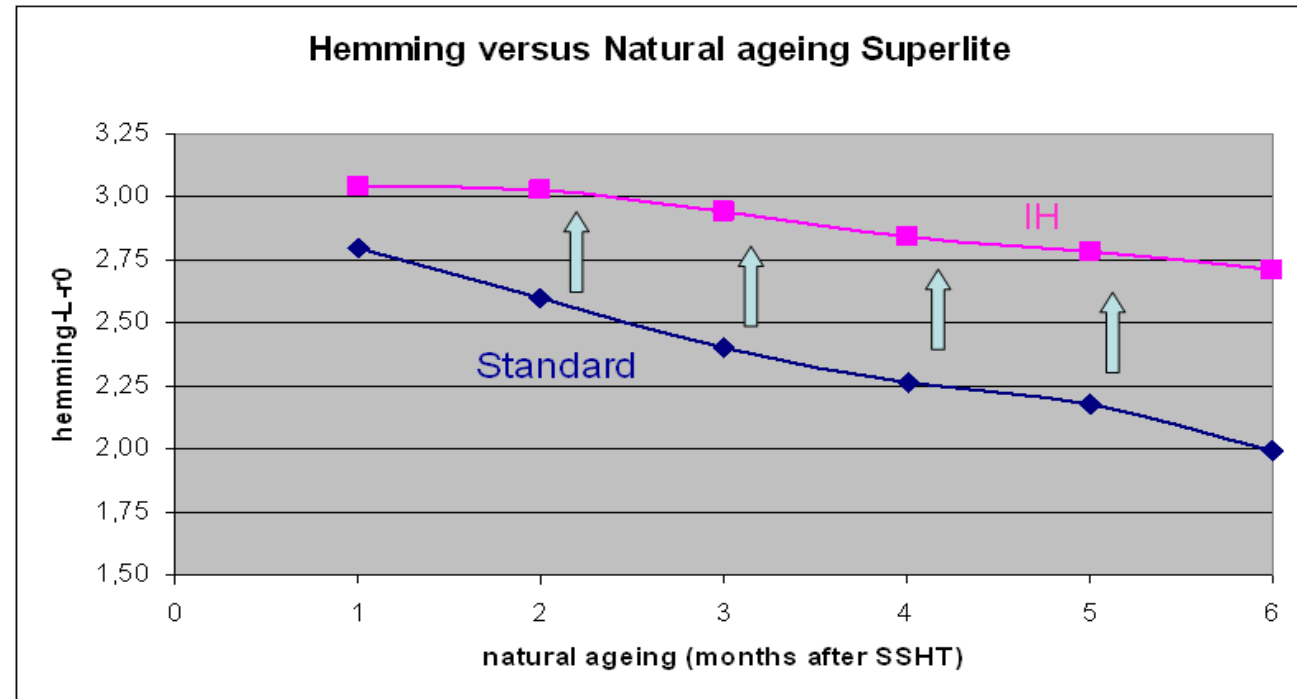

**Superlite<sup>®</sup> 200 IH for Hemming critical panels**

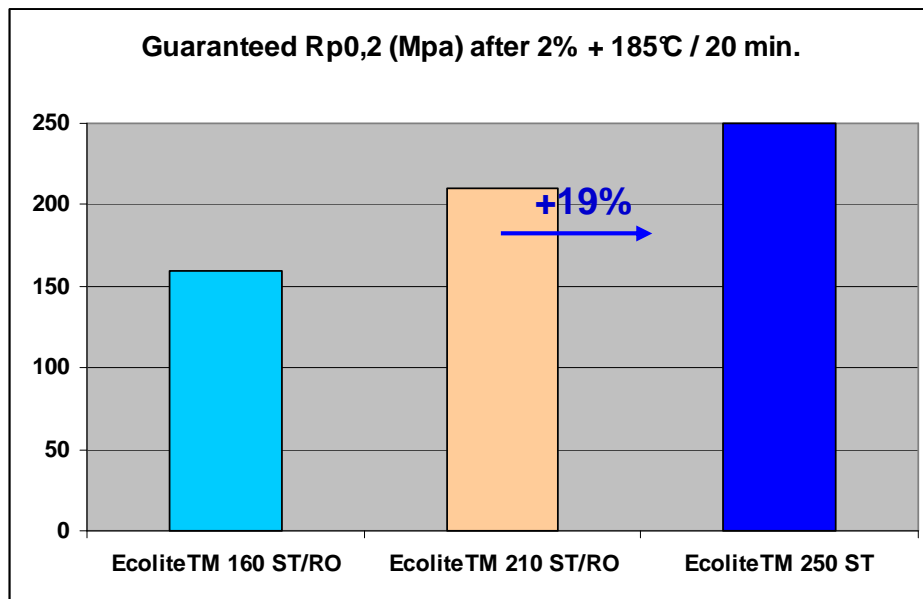

		Ecolite™		
		160 ST/RO	210 ST/RO	250 ST
T4	Rm (Mpa)	200-250	200-250	min.240
As delivered	Rp0,2 (Mpa)	100-140	100-140	120-160
	Au (%)	min.20	min.20	min.20
	A80 (%)	min.23	min.23	min.23
	n 5%	min.0,27	min.0,27	min.0,27
	delta r 10%	max.0,40	max.0,40	max.0,40
after 2 % + 185°C/20 min	Rp0,2 (Mpa)	min.160	min.210	min.250

**Inner Panels = Ecolite™**



# EN 6016 Monosheet Uni-alloy portfolio

	Strength	Hemming	Roping	Formability
<b>Outer panels</b>				
Superlite <sup>®</sup> 160 ST	+	+++	++	+++
Superlite <sup>®</sup> 200 ST	++	++	++	++
Superlite <sup>®</sup> 200 RF	++	++	++++	++
Superlite <sup>®</sup> 200 IH	++	+++	++	++
Superlite <sup>®</sup> 200 IF	++	++	++	+++
Superlite <sup>®</sup> 220 ST	+++	++	++	+
<b>Inner panels &amp; Structural Parts</b>				
Ecolite <sup>™</sup> 160 ST	+	++	-	++
Ecolite <sup>™</sup> 160 RO	+	++	+	++
Ecolite <sup>™</sup> 210 ST	++	++	-	++
Ecolite <sup>™</sup> 210 RO	++	++	+	++
Ecolite <sup>™</sup> 250 ST	++++	+	-	+

**A suitable EN 6016 grade for every panel !**

➤ **Higher formability**

- Superlite 200 ID : improved deep drawing characteristics
- Superlite 200 IF : improved stretch forming characteristics

➤ **Higher strength**

- Superlite 250 ST
- Ecolite 300 ST

➤ **Crash optimised qualities**

- Ecolite C
- Ecolite 260 C

➤ **Sustainability**

- Ecolite Green / Blue



## **SUPPLY REFERENCES**

**Door outer 911 – Superlite 200 IH**



**Bonnet Outer Bentley - Superlite 200 ST**



**Volvo XC60 Bonnet outer –  
Superlite 160 ST**

**Fender BMW 5 – Superlite 200 ST**





**Mercedes E Trunk lid outer - Superlite 200 RF**

**Mercedes S Trunk lid outer - Superlite 200 ST**

**Mercedes CLS Bonnet outer + fender – Superlite 200 ST**

**Mercedes CLS Trunk lid outer – Superlite 200 RF**

**Mercedes E class coupé trunk lid + fender – Superlite 200 ST**

**Audi TT Side panel – Superlite 160 ST**

**Audi TT Roof outer – Superlite 200 ST**

**Audi TT Fender – Superlite 200 ST**

**Audi Q5 Tail gate outer – Superlite 200 ST**

**Audi A6 Door outer – Superlite 200 ST**

**Audi A6 Tail gate – Superlite 200 ST**

**Audi A6 Fender – Superlite 200 RF**

**Audi A7 Fender – Superlite 200 RF**

**Audi A8 Fender – Superlite 200 RF**







**AUTOMOTIVE GRADES 5xxx**

## Typical mechanical values in delivery condition:

EN	Produkt	Mg content	Rp0,2	Rm	A80	n5%
5051A	Aleris 521 1,9	90	185	22		
5754	Aleris 832 2,7	110	215	22,5	0,27	
5754	Aleris 532 3,3	90	215	26	0,29	
5754	Aleris 835 3,2	120	230	24	0,29	
5182	Aleris 843 4,3	135	270	26	0,30	
5182	Innerlite® 4,9	125	275	27	0,32	

Innerlite® : Formability optimised 5182





## **PRETREATMENT AND PASSIVATION**

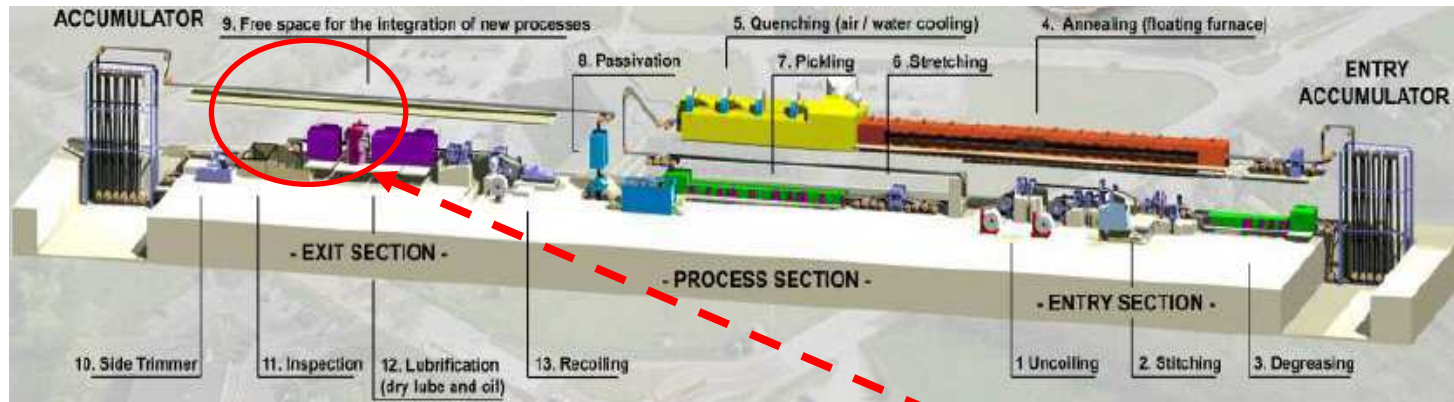

**CALP**  
 thickness 0,8-3.5mm,  
 Width max.2300mm  
 Pre-treatment:  
 hotmelt /  
 passivation

## Hot melts

- Fuchs PL39SX
- Zeller & Gmelin E1
- Houghton DF 521A WF
- Quaker DC1

## Oil

- Fuchs RP4107 LV

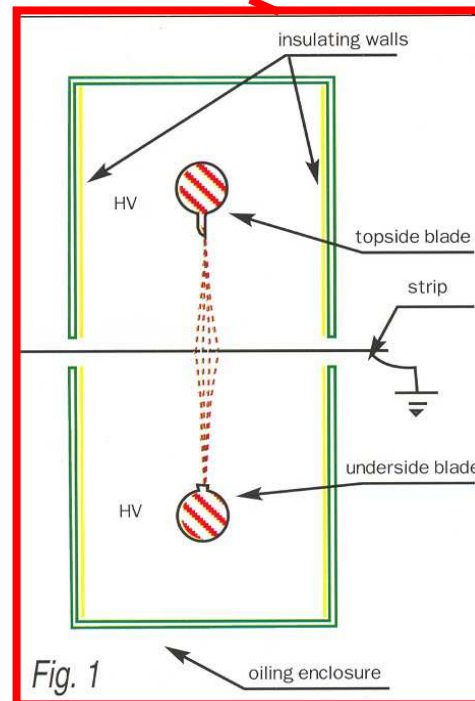

# Chemical Pre-treatment CALP - Passivation

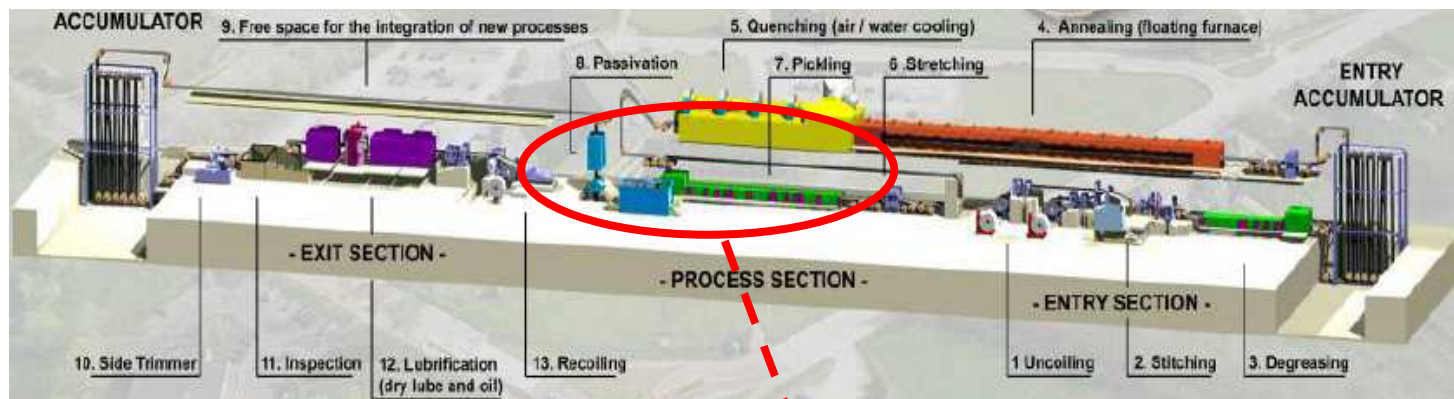

**CALP**  
 thickness 0,8-3.5mm,  
 Width max.2300mm  
 Pre-treatment:  
 hotmelt / passivation

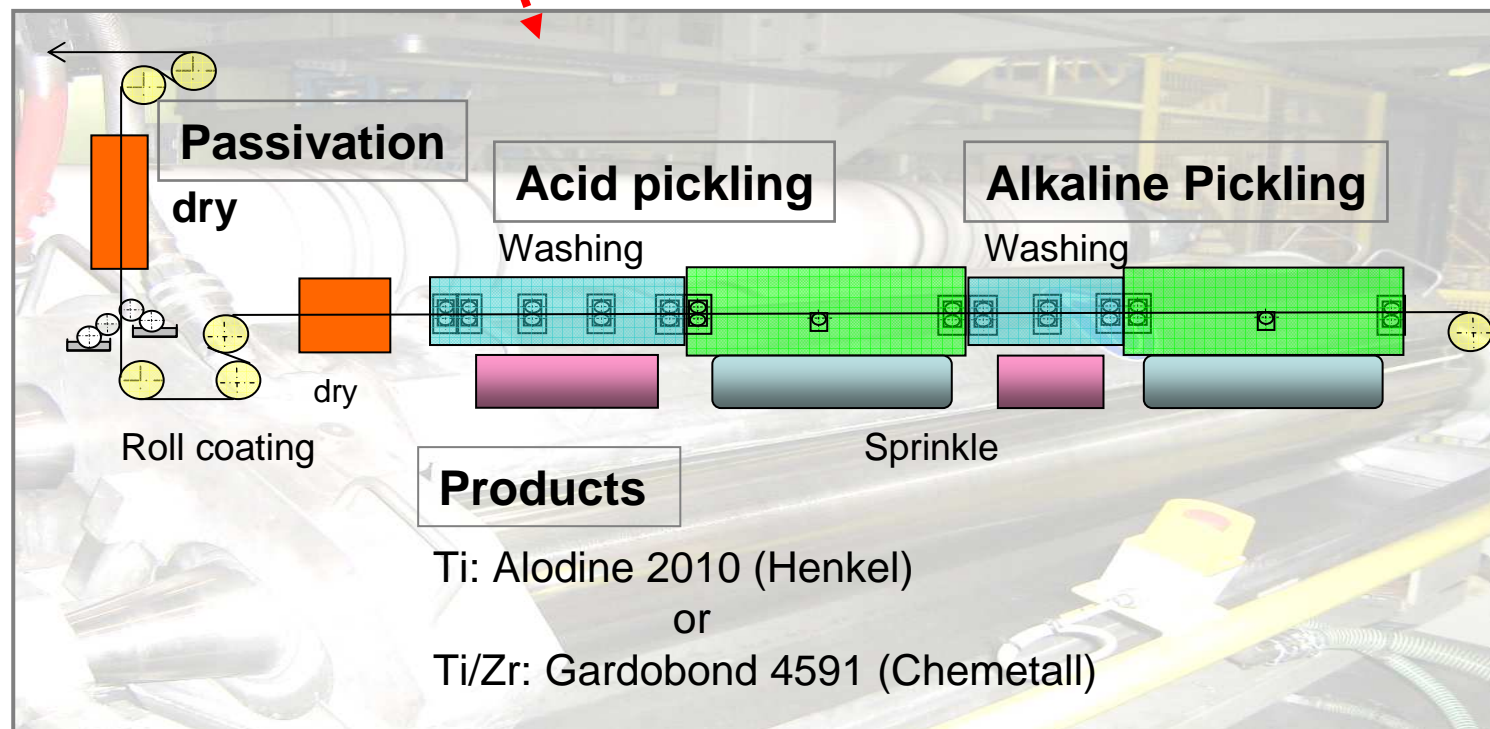



## **7xxx PRODUCT DEVELOPMENT**

## 5xxx / 6xxx alloys

## 7xxx alloys

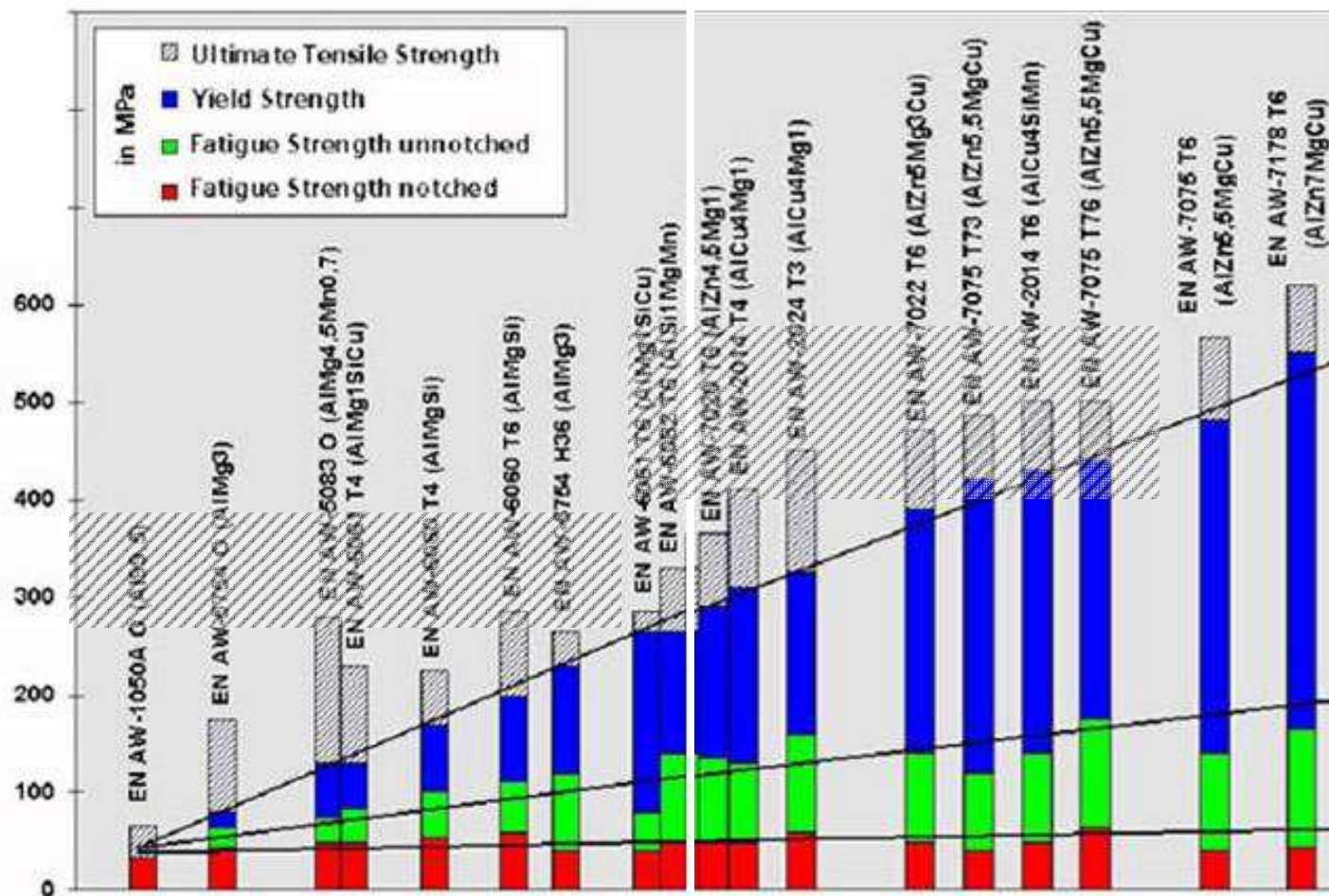
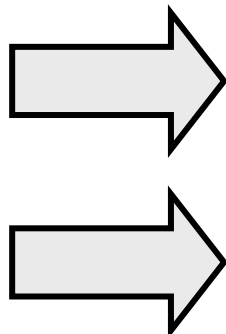

Maximum Strength  $R_{p0.2} \approx 250\text{MPa}$



Maximum Strength  $R_{p0.2} \approx 600\text{MPa}$



**Mature 7xxx alloy technology supplied to a safety critical industry**

## Development approach for Automotive Structural Parts

- Medium strength Al-Zn-Mg system : [Structurlite™400](#)
- High strength Al-Zn-Mg-Cu system : [Structurlite™5xx](#)

**Structurlite™ 400 :  $R_{p0.2}$  400 MPa**

**Structurlite™ 5xx :  $R_{p0.2}$  500 - 590 MPa**



**Boron steel  
2mm**

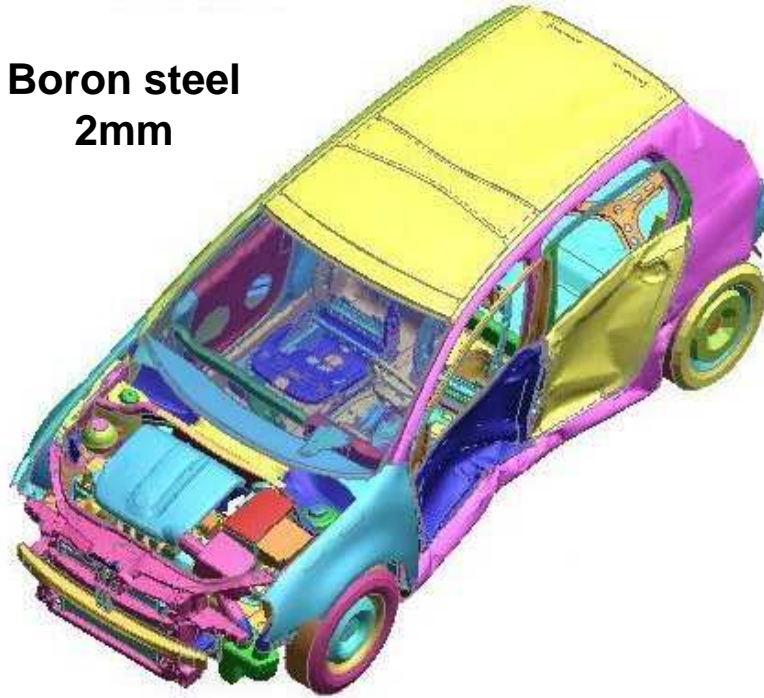

**AA 7xxx  
3.5mm**

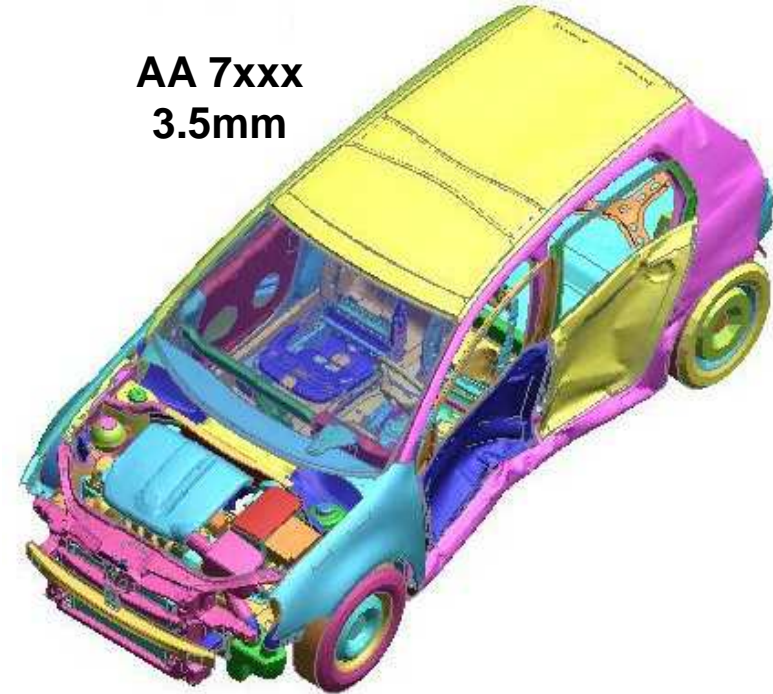

**SLC**

**The crash performance is  
very similar in all results**

**Mass saving with  
aluminium component  
is 40%**

## Forming in T6



Press trial = 27.5mm  
Simulation = 27mm

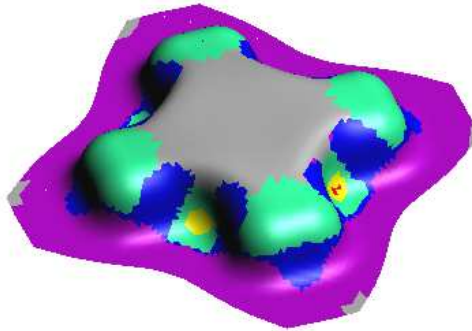

## Forming after Flash Anneal



Press trial = 58mm  
Simulation = 57mm

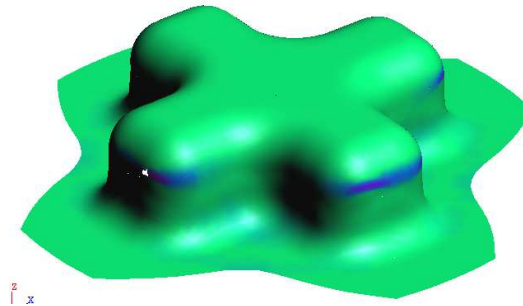

**Flash anneal provides excellent formability**



## Developments 7xxx - Structurlite™ 400 Formability

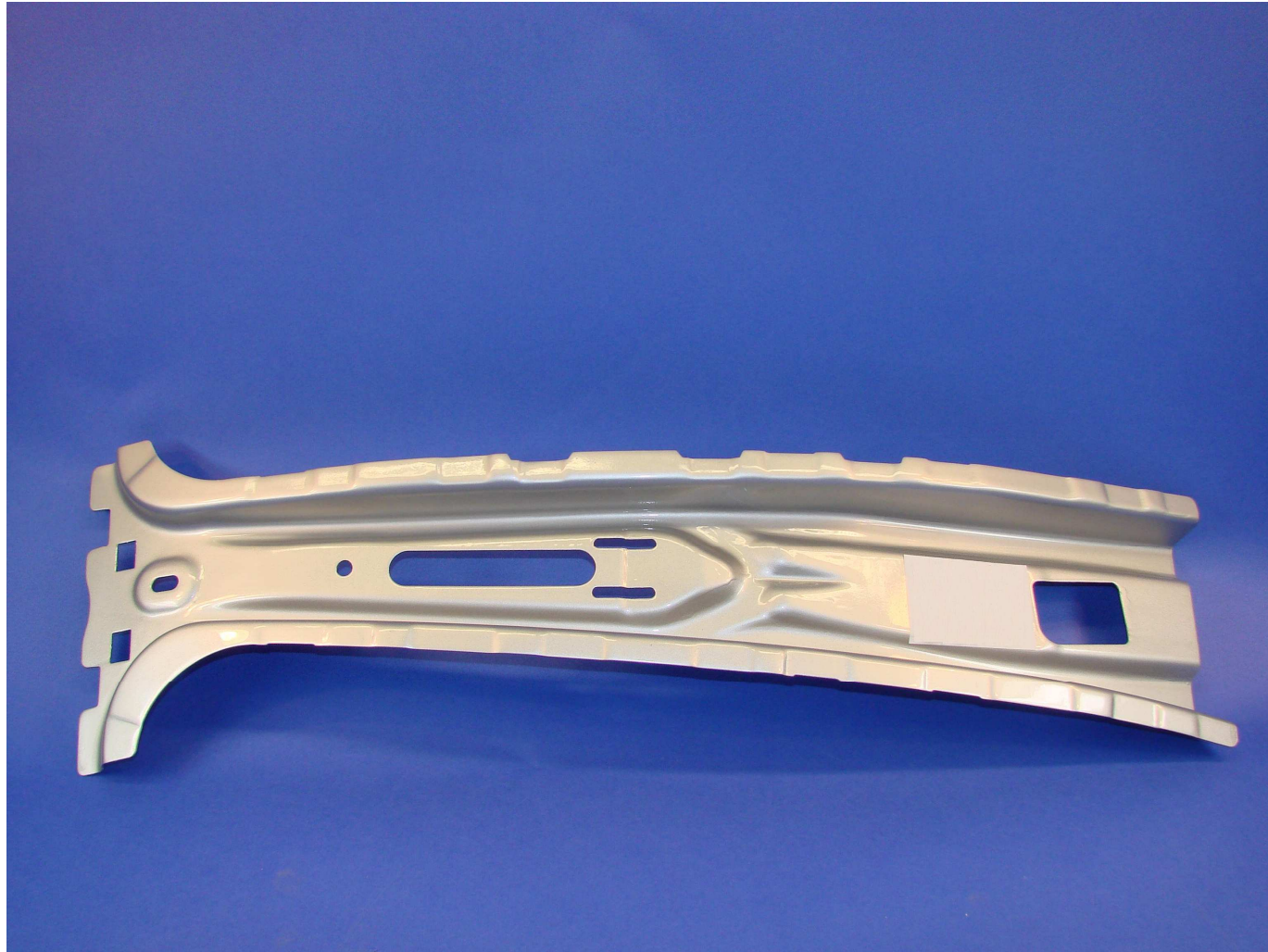

**Flash anneal provides excellent formability**



## **R & D SET UP**

## Steering

- Aleris Management
- PMTs

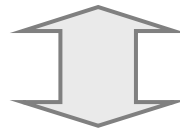
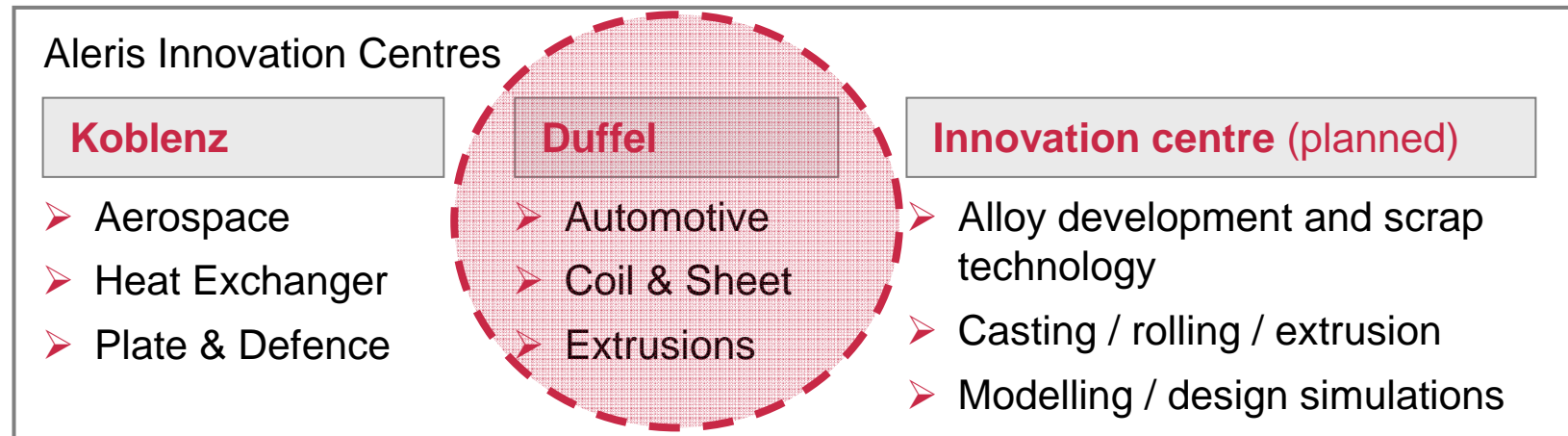

## External collaborations

- Universities
- Independent research centres
- Customers

Q & A ?

[Dirk.Van.Nieuwerburgh@aleric.com](mailto:Dirk.Van.Nieuwerburgh@aleric.com)

Phone: +32 15 30 26 26

**Thank you for your attention**